

DLM

TOP-OF-DOCK by

Surface-mounted dock levelers for low dock heights

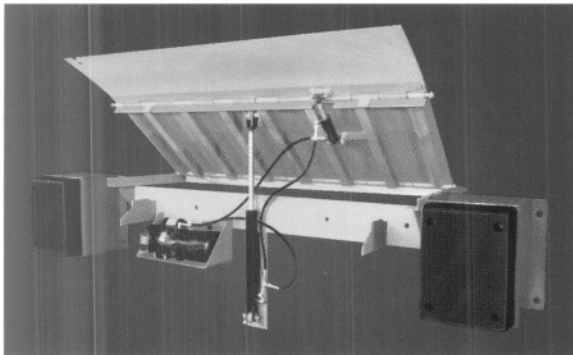
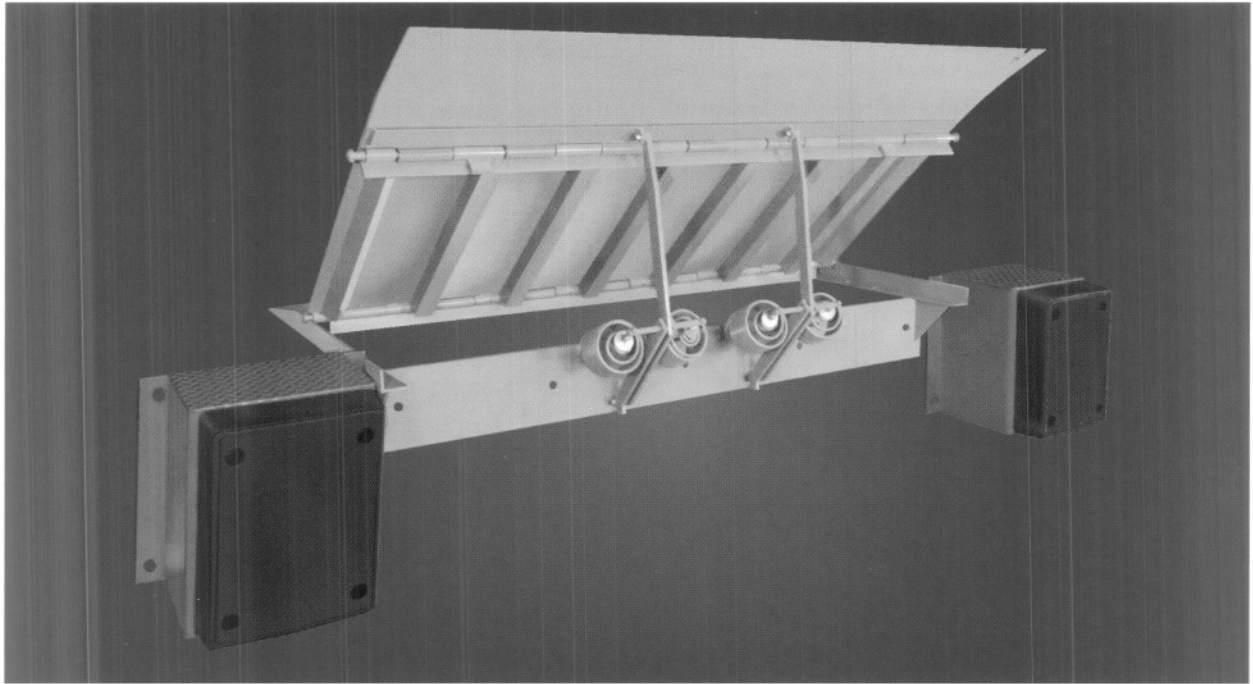

WITH THE INVENTION OF THE TOP-OF-DOCK LEVELER, DLM CREATED A PRACTICAL WAY TO EFFICIENTLY MOVE FREIGHT OVER DOCKS THAT ARE BELOW INDUSTRY STANDARD IN HEIGHT

*Available with mechanical or hydraulic operation.
Mechanical (SM-500) model shown in large photo.
Hydraulic (HSM-500) model shown in small photo.*

VALUE-ENGINEERED
DOCK LEVELERS & EQUIPMENT

TOP-OF-DOCK by



America's favorite surface-mounted dock levelers

■ LASTING EFFICIENCY

DLM invented the top-of-dock leveler in 1963 as a rugged and economical choice for older docks that are below the 50" industry standard height. The DLM top-of-dock leveler allows a 10" upward reach from the dock to the trailer, so that low docks can remain useful. DLM top-of-dock levelers are the industry standard for surface-mounted dock levelers, and are by far the most popular choice of motor freight industry professionals when they are working at low docks. The initial cost is low. They're easy and safe to operate. Their rugged design requires little maintenance.

These are quality-made dock levelers that will provide you with years of dependable operation. Deck and lip are constructed with high-strength steel safety tread plate (minimum yield of 55,000 psi on 20,000 lb. capacity units and 70,000 psi on 25,000 lb. capacity units). Long-life hinges include grease fittings throughout. Bump blocks are our Extra-Heavy-Duty Series, in a tall configuration, with our Tuf-Cord® rubber bumpers, the toughest in the industry.

■ MECHANICAL OR HYDRAULIC

DLM top-of-dock levelers are offered with mechanical or hydraulic operation – in your choice of 20,000 or 25,000 lb. capacity. Mechanical models are equipped with a lip hook. Hydraulic models are equipped with a 120V 1P pump motor and a NEMA 12 push-button control.

■ SIMPLE INSTALLATION

DLM top-of-dock levelers mount directly to the floor and edge of a loading dock. No pit is needed. Space requirement is minimal – only 35" back from the dock edge.

■ OPTIONS

Ask about our wide variety of ramp approach plates, face plates, and formed angles. We have the exact material you need – in stock and at the right price!

- 17" lip for trailers with step sections
- Key lock operation (hydraulic only)
- Rust-inhibiting primer coat.
- Grey bump blocks (orange is standard)
- Tapered lip (tapered at sides).
- Wall mounting bracket for lifting hook.
- Abrasive deck surface.
- Upgrade to 70,000 psi minimum yield steel safety tread plate on 20,000 lb. capacity units.
- Dock ladder.

■ WE ARE TOTAL QUALITY

DLM is a total-quality company with an intensive and all-encompassing quality control program. Every aspect of our products – from the raw steel to the finishing coat of paint – is closely-monitored to assure that your every expectation for quality and durability is met.

Edge-of-dock, top-of-dock, and pit-mounted levelers...no matter which type of leveler you need, DLM offers you the best engineering, highest quality, and greatest value. We invented the edge of-dock leveler and the top-of-dock leveler, and have more in service than all other companies combined. DLM dock levelers are the number one choice of America's leading freight handling professionals, the motor freight industry. Consult DLM for the dock leveler that's best for your application.

Model Number	Lift Mechanism	Deck Width	Length	Capacity
SM500	Mechanical operation, four extension springs	72" (183 cm)	63" (160 cm)	20000 lbs. (9070 kg)
SM525	"	"	"	25000 lbs. (11338 kg)
HSM500	Hydraulic operation, twin cylinders	"	"	20000 lbs. (9070 kg)
HSM525	"	"	"	25000 lbs. (11338 kg)



DLM, Inc. • P.O. Box 37 • Highway 270 E. • Malvern, Arkansas 72104 • 501-332-5495 • FAX 501-337-4537
FOR PURCHASING INFORMATION CALL: 800-643-5423 • FAX 501-337-7750

Due to continued product improvement and changes in industry standards, DLM reserves the right to change specifications without notice or obligation.

DLM Dock Levelers are covered by one or more of these U.S. Patent Numbers: 4,944,062 • 4,935,979 • 4,827,549 • 5,123,135
5,203,663 • 5,195,205 • 5,214,818 • 5,343,583.